



Key Parameters

V_{DRM} / V_{RRM}	6500 V
I_{TAVM}	540 A ($T_C=85^\circ\text{C}$)
I_{TSM}	10500 A
V_{T0}	1,35 V
r_T	1,4 m Ω
R_{thJC}	21 K/kW
Clamping Force	13...23 kN
Max. Diameter	76 mm
Contact Diameter	50 mm
Height	26 mm



For type designation please refer to actual shortform catalog

Merkmale

- Volle Sperrfähigkeit 50/60Hz über einen weiten Temperaturbereich
- Hermetisch dichtes Keramikgehäuse
- Hohe Stoßstrombelastbarkeit
- Hohe Einschaltfähigkeit di/dt

Features

- Full blocking 50/60Hz over a wide range temperature range
- Hermetically sealed ceramic package
- High surge current capability
- High di/dt turn on capability

Typische Anwendungen

- Mittelspannungssanftanlasser
- Gleichrichter für Antriebsapplikationen
- Mittelspannungsumrichter

Typical Applications

- Medium Voltage Softstarter
- Rectifier for Drives Applications
- Medium voltage converters



content of customer DMX code	DMX code digit	DMX code digit quantity
serial number	1..7	7
SP material number	8..16	9
datecode (production day)	17..18	2
datecode (production year)	19..20	2
datecode (production month)	21..22	2
vT class (optional)	23..26	4
QR class (optional)	27..30	4

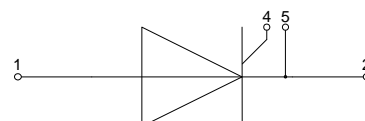



Technische Information / technical information



**Netz-Thyristor
Phase Control Thyristor**

T570N

Infineon Technologies Bipolar
GmbH & Co. KG

Elektrische Eigenschaften / electrical properties Höchstzulässige Werte / maximum rated values

Periodische Vorwärts- und Rückwärts-Spitzensperrspannung repetitive peak forward off-state and reverse voltage	$T_{vj} = 25^\circ\text{C} \dots T_{vj\text{max}}$	$V_{\text{DRM}}, V_{\text{RRM}}$	6500	V
Durchlaßstrom-Grenzeffektivwert maximum RMS on-state current	$T_C = 85^\circ\text{C}$	I_{TRMSM}	850	A
Dauergrenzstrom average on-state current	$T_C = 85^\circ\text{C}$ $T_C = 70^\circ\text{C}$ $T_C = 55^\circ\text{C}$	I_{TAVM}	540 660 760	A A A
Stoßstrom-Grenzwert surge current	$T_{vj} = 25^\circ\text{C}, t_p = 10\text{ ms}$ $T_{vj} = T_{vj\text{max}}, t_p = 10\text{ ms}$	I_{TSM}	10500 9400	A A
Grenzlastintegral I^2t -value	$T_{vj} = 25^\circ\text{C}, t_p = 10\text{ ms}$ $T_{vj} = T_{vj\text{max}}, t_p = 10\text{ ms}$	I^2t	551,25 441,8	$10^3\text{ A}^2\text{s}$ $10^3\text{ A}^2\text{s}$
Kritische Stromsteilheit critical rate of rise of on-state current	DIN IEC 60747-6 $f = 50\text{ Hz}, i_{\text{GM}} = 3\text{ A}, di_{\text{G}}/dt = 6\text{ A}/\mu\text{s}$	$(di_{\text{T}}/dt)_{\text{cr}}$	150	$\text{A}/\mu\text{s}$
Kritische Spannungssteilheit critical rate of rise of off-state voltage	$T_{vj} = T_{vj\text{max}}, V_{\text{D}} = 0,67 V_{\text{DRM}}$ 5.Kennbuchstabe / 5 th letter F	$(dv_{\text{D}}/dt)_{\text{cr}}$	1000	$\text{V}/\mu\text{s}$

Charakteristische Werte / characteristic values

Durchlaßspannung on-state voltage	$T_{vj} = T_{vj\text{max}}, i_{\text{T}} = 1000\text{A}$	v_{T}	max. 2,75	V
Schleusenspannung threshold voltage	$T_{vj} = T_{vj\text{max}}$	$V_{(\text{TO})}$	max. 1,35	V
Ersatzwiderstand slope resistance	$T_{vj} = T_{vj\text{max}}$	r_{T}	max. 1,4	m Ω
Durchlaßkennlinie on-state characteristic $100\text{A} \leq i_{\text{T}} \leq 2700\text{A}$ $v_{\text{T}} = A + B \cdot i_{\text{T}} + C \cdot \ln(i_{\text{T}} + 1) + D \cdot \sqrt{i_{\text{T}}}$	$T_{vj} = T_{vj\text{max}}$	max.	A -0,3296 B 0,001724 C 0,4376 D -0,05275	
Zündstrom gate trigger current	$T_{vj} = 25^\circ\text{C}, V_{\text{D}} = 12\text{ V}$	I_{GT}	max. 350	mA
Zündspannung gate trigger voltage	$T_{vj} = 25^\circ\text{C}, V_{\text{D}} = 12\text{ V}$	V_{GT}	max. 2,5	V
Nicht zündender Steuerstrom gate non-trigger current	$T_{vj} = T_{vj\text{max}}, V_{\text{D}} = 12\text{ V}$ $T_{vj} = T_{vj\text{max}}, V_{\text{D}} = 0,5 V_{\text{DRM}}$	I_{GD}	max. 20 max. 10	mA mA
Nicht zündende Steuerspannung gate non-trigger voltage	$T_{vj} = T_{vj\text{max}}, V_{\text{D}} = 0,5 V_{\text{DRM}}$	V_{GD}	max. 0,4	V
Haltestrom holding current	$T_{vj} = 25^\circ\text{C}, V_{\text{D}} = 12\text{ V}$	I_{H}	max. 350	mA
Einraststrom latching current	$T_{vj} = 25^\circ\text{C}, V_{\text{D}} = 12\text{ V}, R_{\text{GK}} \geq 10\ \Omega$ $i_{\text{GM}} = 3\text{ A}, di_{\text{G}}/dt = 6\text{ A}/\mu\text{s}, t_{\text{g}} = 20\ \mu\text{s}$	I_{L}	max. 3	A
Vorwärts- und Rückwärts-Sperrstrom forward off-state and reverse current	$T_{vj} = T_{vj\text{max}}$ $V_{\text{D}} = V_{\text{DRM}}, V_{\text{R}} = V_{\text{RRM}}$	$i_{\text{D}}, i_{\text{R}}$	max. 400	mA
Zündverzug gate controlled delay time	DIN IEC 60747-6 $T_{vj} = 25^\circ\text{C}, i_{\text{GM}} = 3\text{ A}, di_{\text{G}}/dt = 6\text{ A}/\mu\text{s}$	t_{gd}	max. 2,5	μs

prepared by:	TM	date of publication:	2014-06-18
approved by:	JP	revision:	2.3



Technische Information / technical information



Netz-Thyristor Phase Control Thyristor

T570N

Infineon Technologies Bipolar
GmbH & Co. KG

Elektrische Eigenschaften / electrical properties Charakteristische Werte / characteristic values

Freiwerdezeit circuit commutated turn-off time	$T_{vj} = T_{vj\max}$, $i_{TM} = I_{TAVM}$ $V_{RM} = 100\text{ V}$, $V_{DM} = 0,67 V_{DRM}$ $dv_D/dt = 20\text{ V}/\mu\text{s}$, $-di_T/dt = 10\text{ A}/\mu\text{s}$ 4. Kennbuchstabe / 4 th letter O	t_q	typ.	1000	μs
Sperrverzögerungsladung recovered charge	$T_{vj} = T_{vj\max}$ $i_{TM} = 2 I_{TAVM}$, $-di_T/dt = 10\text{ A}/\mu\text{s}$ $V_R = 3000\text{ V}$, $V_{RM} \leq 0,8V_{RRM}$ $R = 83\Omega$; $C = 0,44\mu\text{F}$	Q_r	max.	6,2	mAs
Rückstromspitze peak reverse recovery current	$T_{vj} = T_{vj\max}$ $i_{TM} = 2 I_{TAVM}$, $-di_T/dt = 10\text{ A}/\mu\text{s}$ $V_R = 3000\text{ V}$, $V_{RM} \leq 0,8V_{RRM}$ $R = 83\Omega$; $C = 0,44\mu\text{F}$	I_{RM}	max.	190	A

Thermische Eigenschaften / thermal properties

Innerer Wärmewiderstand thermal resistance, junction to case	<u>Kühlfläche / cooling surface</u> beidseitig / two-sided, $\theta = 180^\circ\text{sin}$ beidseitig / two-sided, DC Anode / anode, DC Kathode / cathode, DC	R_{thJC}	max.	23,0	K/kW
			max.	21,0	K/kW
			max.	37,5	K/kW
			max.	48,0	K/kW
Übergangs-Wärmewiderstand thermal resistance, case to heatsink	<u>Kühlfläche / cooling surface</u> beidseitig / two-sided einseitig / single-sided	R_{thCH}	max.	5,0	K/kW
			max.	10,0	K/kW
Höchstzulässige Sperrschichttemperatur maximum junction temperature		$T_{vj\max}$		125	$^\circ\text{C}$
Betriebstemperatur operating temperature		$T_{c\text{op}}$		-40...+125	$^\circ\text{C}$
Lagertemperatur storage temperature		T_{stg}		-40...+150	$^\circ\text{C}$

Mechanische Eigenschaften / mechanical properties

Gehäuse, siehe Anlage case, see annex				Seite 4 page 4	
Si-Element mit Druckkontakt Si-pellet with pressure contact					
Anpresskraft clamping force		F		13...23	kN
Steueranschlüsse control terminals	DIN 46244 Gate			$\varnothing 1,5 \times 3,2$	mm
	Kathode /Cathode			A 2,8x0,5	mm
				A 4.8x0,5	mm
Gewicht weight		G	typ.	550	g
Kriechstrecke creepage distance				20	mm
Schwingfestigkeit vibration resistance	f = 50 Hz			50	m/s ²

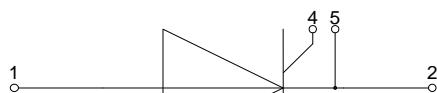
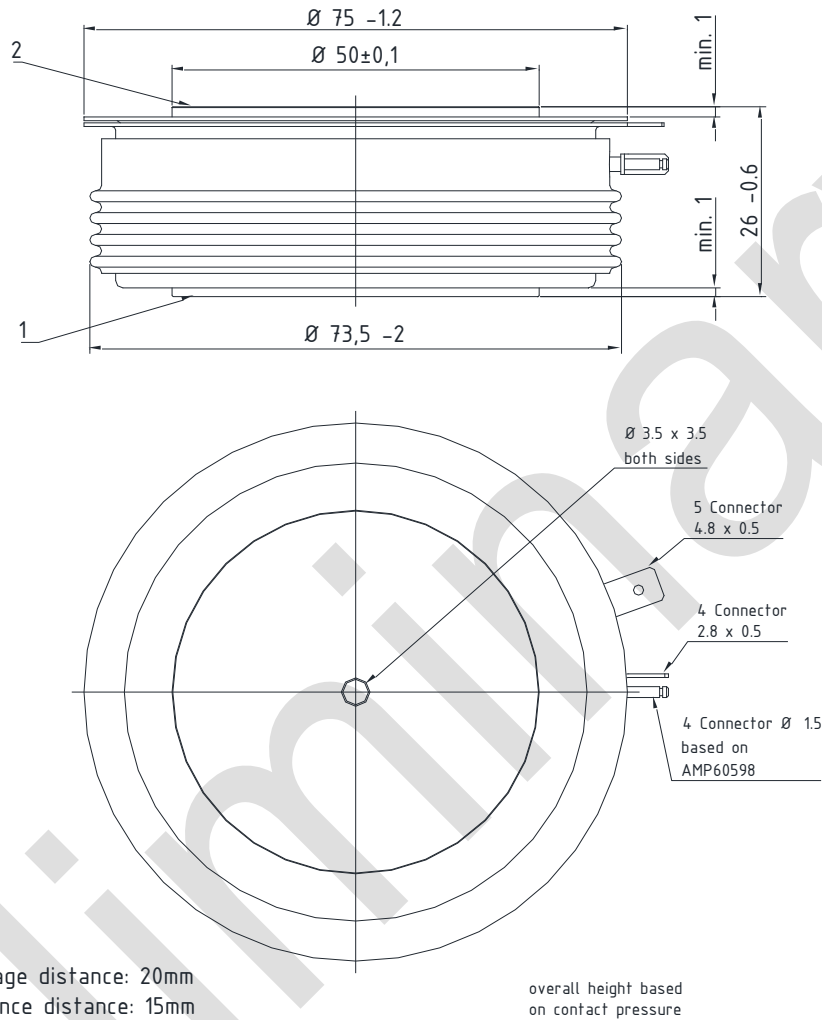

- 1: Anode/anode
- 2: Kathode/cathode
- 4: Gate